

Adattabile a : **SCANIA GR900(H) - GR900R (W/Retarder)**
 Suitable To :

Oil Seal & Gasket Kit
74 - 75 - 76

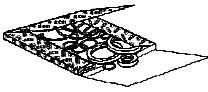

Oil Pump
69



Oil Filter
70



Oil Filter
71



Kits

x 4	x 8
x 4	x 8
x 4	x 8
Kit 72	Kit 73

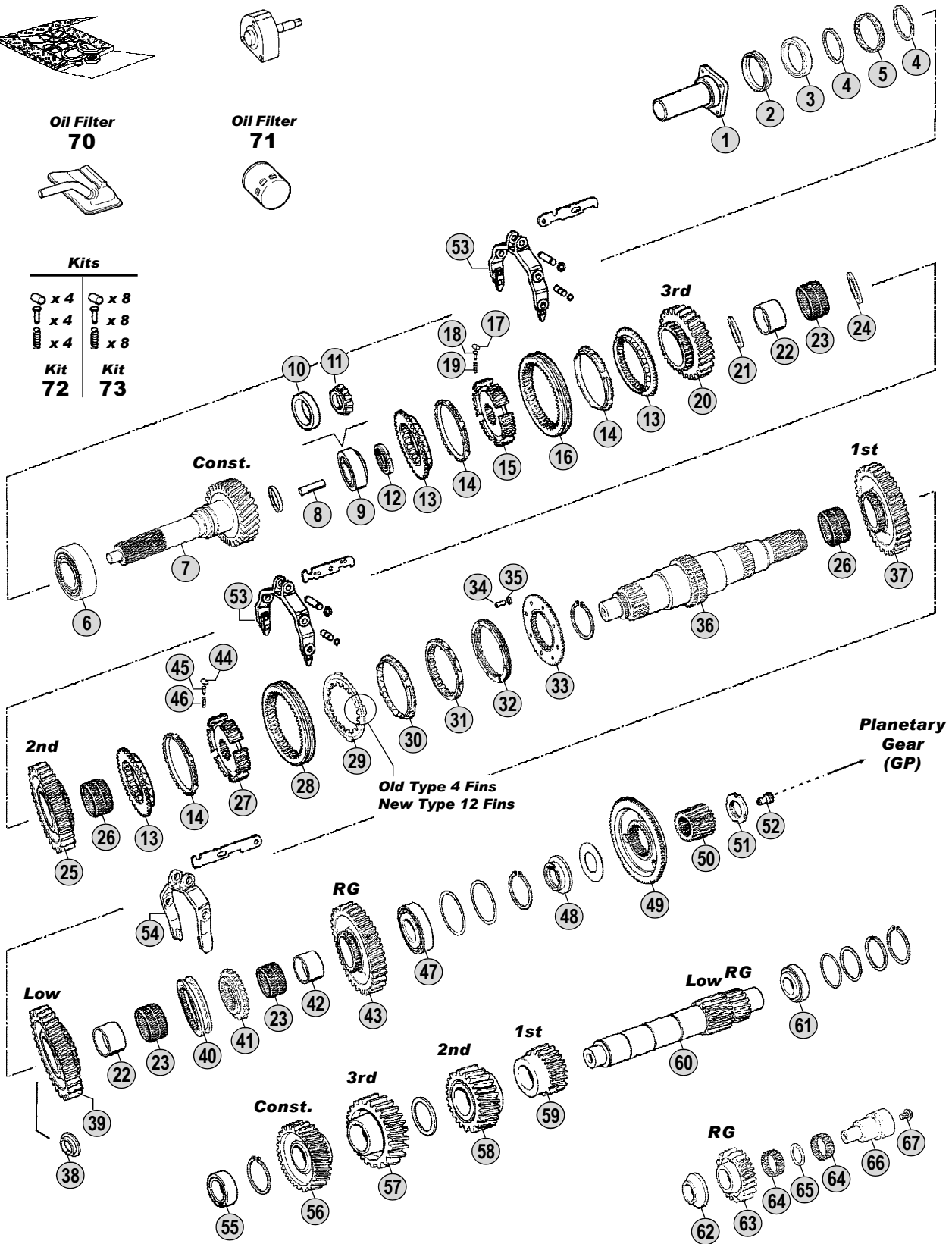

All original equipment manufacturers numbers, symbols, pictures and description used in this catalogue are for reference only, and it is not implied that any part listed is the product of these manufacturers. Tutti i nostri particolari non sono originali ma con essi intercambiabili. I riferimenti originali, le figure, i modelli sono esposti a semplice titolo indicativo. La nostra produzione riporta il nostro marchio.

Models

Serie 3 - Serie 4

G93 - P93 - R93 - T93 - P113 - R113 - T113 - R143 - T143

94C/D/G/L - 114C/G/L - 124C/G/L - 144C/G/L



Fig.	CEI no.	Rif. SCANIA	Description	Q.ty	Note					
						GR900	GRH900	GR900R		
1	135.156	1103934	Cover	1		●	●	●		
2	139.569	378613	V-Ring D.45	1		●	●	●		
3	139.567	1318388	Oil Seal 55x75x9	1		●	●	●		
4	139.582	1515004	Ring	2		●	●	●		
5	139.583	1114315	Ring	1		●	●	●		
6	130.528	1327878	Bearing D.65x150x40	1	Oem	●	●	●		
6	530.528	1327878	Bearing D.65x150x40	1	A.Market	●	●	●		
7	102.335	1377308	Input Shaft 26 T	1		●	●	●		
7	102.336	1378580	Input Shaft 26 T	1	EK-PTO	●	●	●		
8	189.502	315060	Oil tube	1		●	●	●		
9	130.621	361043	Bearing 40x85x33	1	Oem Old Type	●	●	●		
9	530.621	361043	Bearing 40x85x33	1	A.Market Old Type	●	●	●		
10	130.529	1548819	Bearing Cone 85 mm	1	Oem New Type	●	●	●		
10	530.529	1548819	Bearing Cone 85 mm	1	A.Market New Type	●	●	●		
11	130.530	1883975	Roller Bearing 40x30 mm	1	New Type	●	●	●		
12	187.647	1461414	Nut	1		●	●	●		
13	109.165	1116477	Synchronizer Cone	3		●	●	●		
14	119.145	1382465	Synchronizer Ring	3	(C)	●	●	●		
14	119.236	1756447	Synchronizer Ring	3	(D)	●	●	●		
15	157.662	1121658	Synchronizer Hub	1		●	●	●		
16	154.194	369906	Sliding Sleeve	1	(C)	●	●	●		
16	154.386	1529939	Sliding Sleeve	1	(D)	●	●	●		
17	160.198	374334	Roller	4		●	●	●		
18	160.199	369910	Pin	4		●	●	●		
19	156.177	369911	Spring	4		●	●	●		
20	145.750	1109586	Gear 3rd Speed 30 T	1		●	●	●		
21	169.911	1109585	Spacer	1		●	●	●		
22	117.366	1304852	Bush	2		●	●	●		
23	137.170	378628	Needle Cage D.80x88x40	3		●	●	●		
24	169.905	1104049	Spacer	1		●	●	●		
25	145.751	1109588	Gear 2nd Speed 32 T	1		●	●	●		
26	137.171	378616	Needle Cage D.80x88x55	2		●	●	●		
27	157.552	1376499	Synchronizer Hub	1		●	●	●		
28	154.195	1111295	Sliding Sleeve 1st-2nd Speed	1	(C)	●	●	●		
28	154.386	1529939	Sliding Sleeve	1	(D)	●	●	●		
29	169.740	1401622	Driver Plate	1	(C)(1) New Style 12 Fins	●	●	●		
29	169.848	1533848	Driver Plate	1	(D)	●	●	●		
30	119.146	1401620	Synchronizer Ring	1	(C)(1) New Style 12 Fins	●	●	●		
30	119.202	1529950	Synchronizer Ring	1	(D)	●	●	●		
31	119.203	1438526	Synchronizer Ring	1		●	●	●		
32	119.147	1383895	Intermediate Synchro Ring	1	(C)	●	●	●		
32	119.235	1466318	Intermediate Synchro Ring	1	(D)	●	●	●		
33	109.166	1300061	Synchronizer Cone	1		●	●	●		
34	160.193	1340002	Pin	8		●	●	●		
35	111.197	383138	Lock Ring	8		●	●	●		

Notes

- (A) Up to gearbox no. 6669319 (B) From gearbox no. 6669320
 (C) Standard Generation. Use items marked (C) together.
 (D) LATEST GENERATION. Use items marked (D) together.
 (1) Old style with 4 fins not listed in the catalogue. The old ring 391804 (fig.29) and the old Synchro ring 373272 (fig.30) can be replaced by :
 1 pc. 169.740 - 1401622 (Fig.29) + 1 pc. 119.146 - 1401620 (Fig.30)

(*) Old and New Gen. Can be replaced by synchro rebuilt kit 298.188 (Latest Gen.) shown in the next table
 (@) LATEST GENERATION. To be coupled together.

Date

05 / 2010

Table

0150



HIGH FIDELITY SPARE PARTS

Adattabile a : **SCANIA GR900(H) - GR900R (W/Retarder)**
 Suitable To :

Oil Seal & Gasket Kit
74 - 75 - 76



Oil Pump
69



Oil Filter
70



Oil Filter
71



Kits

x 4	x 8
x 4	x 8
x 4	x 8
Kit 72	Kit 73

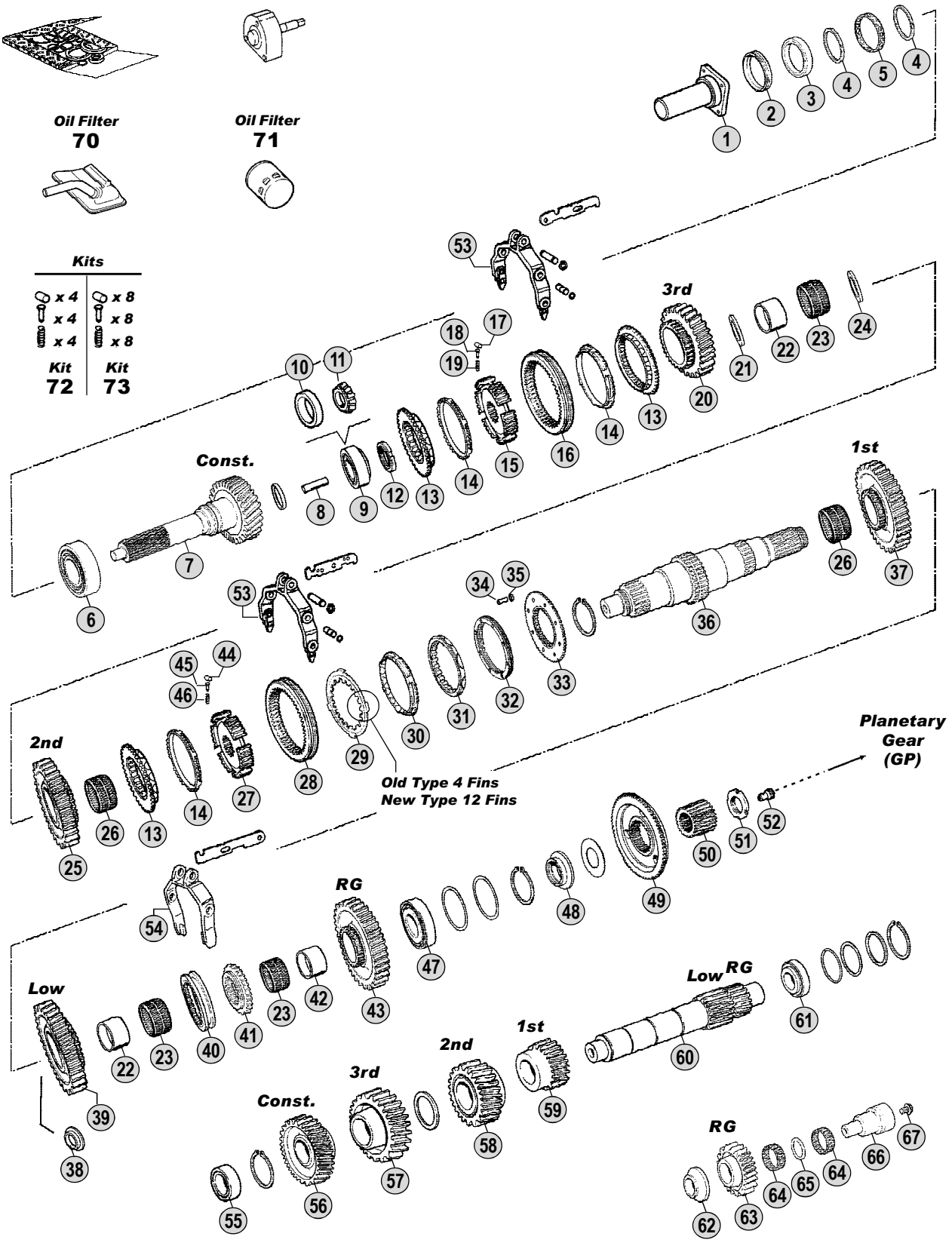

All original equipment manufacturers numbers, symbols, pictures, models and description used in this catalogue are for reference only, and it is not implied that any part listed is the product of these manufacturers. Tutti i nostri particolari non sono originali ma con essi intercambiabili. I riferimenti originali, le figure, i modelli sono esposti a semplice titolo indicativo. La nostra produzione riporta il nostro marchio.

Models

Serie 3 - Serie 4
G93 - P93 - R93 - T93 - P113 - R113 - T113 - R143 - T143
94C/D/G/L - 114C/G/L - 124C/G/L - 144C/G/L



Fig.	CEI no.	Rif. SCANIA	Description	Q.ty	Note					
						GR900	GRH900	GR900R		
36	103.179	1325345	Main Shaft	1	(A)	●	●	●		
36	103.170	1387295	Main Shaft	1	(B)	●	●	●		
37	145.752	1846635	Gear 1st Speed 35 T	1		●	●	●		
38	169.912	1109594	Spacer	1		●	●	●		
39	145.753	1109592	Gear Low 38 T	1		●	●	●		
40	154.330	378646	Sliding Sleeve	1		●	●	●		
41	157.668	378627	Fixed Hub	1		●	●	●		
42	117.365	1304853	Bush	1		●	●	●		
43	147.210	1111899	Reverse Gear Z 37	1		●	●	●		
44	160.198	374334	Roller	4		●	●	●		
45	160.199	369910	Pin	4		●	●	●		
46	156.177	369911	Spring	4		●	●	●		
47	130.528	1327878	Bearing D.65x150x40	1	Oem	●	●	●		
47	530.528	1327878	Bearing D.65x150x40	1	A.Market	●	●	●		
48	169.910	1113910	Spacer	1		●	●	●		
49	109.190	1304850	Synchronizer Cone	1	(*) Old Generation	●	●	●		
49	109.420	1789444	Synchronizer Cone	1	(*) New Generation	●	●	●		
49	109.755	1883354	Synchronizer Cone	1	(@) Latest Generation	●	●	●		
50	157.549	1459308	Sun Gear 24 T	1		●	●			
50	157.554	1459309	Sun Gear 24 T	1				●		
51	187.648	1461417	Nut	1		●	●			
51	187.649	1461416	Nut	1				●		
52	189.616	1314986	Oil Plug	1	(A)	●	●	●		
52	189.617	1387297	Oil Plug	1	(B)	●	●	●		
53	141.171	1327286	Fork	2		●	●	●		
54	141.180	1305971	Fork	1		●	●	●		
55	130.295	1903570	Bearing D.50x100x37,65	1	Oem	●	●	●		
55	530.295	1903570	Bearing D.50x100x37,65	1	A.Market	●	●	●		
56	146.548	1322290	Constant Gear 40 T	1		●	●	●		
57	146.549	1322291	Gear 3rd Speed 34 T	1		●	●	●		
58	146.550	1322292	Gear 2nd Speed 26 T	1		●	●	●		
59	146.551	1322293	Gear 1st Speed 20 T	1		●	●	●		
60	105.168	1109595	Countershaft 13 T	1		●	●	●		
61	130.532	1357711	Bearing 60X130X33,5	1	Oem	●	●	●		
61	530.532	1357711	Bearing 60X130X33,5	1	A.Market	●	●	●		
62	169.907	378614	Washer	1		●	●	●		
63	147.211	1111901	Reverse Gear 23 T	1		●	●	●		
64	137.172	378615	Needle Cage D.50x62x21,5	2		●	●	●		
65	169.908	380109	Spacer	1		●	●	●		
66	147.203	1510337	Reverse Pin	1		●	●	●		
67	187.650	812534	Screw	1		●	●	●		
69	280.540	1426449	Oil Pump	1		●	●	●		
70	280.611	1307097	Oil Filter	1		●	●	●		
71	280.612	1768402	Oil Filter	1		●	●	●		
72	198.847	CEI 198847	Roller-Pins and Springs kit	1		●	●	●		

Notes

- (A) Up to gearbox no. 6669319 (B) From gearbox no. 6669320
 (C) Standard Generation. Use items marked (C) together.
 (D) LATEST GENERATION. Use items marked (D) together.
 (1) Old style with 4 fins not listed in the catalogue. The old ring 391804 (fig.29) and the old Synchro ring 373272 (fig.30) can be replaced by:
 1 pc. 169.740 - 1401622 (Fig.29) + 1 pc. 119.146 - 1401620 (Fig.30)

(*) Old and New Gen. Can be replaced by synchro rebuilt kit 298.188 (Latest Gen.) shown in the next table
 (@) LATEST GENERATION. To be coupled together.

Date

05 / 2010

Table

0150

Adattabile a : **SCANIA GR900(H) - GR900R (W/Retarder)**
 Suitable To :

Oil Seal & Gasket Kit
74 - 75 - 76

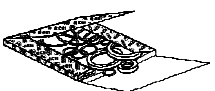

Oil Pump
69



Oil Filter
70



Oil Filter
71



Kits

x 4	x 8
x 4	x 8
x 4	x 8
Kit 72	Kit 73

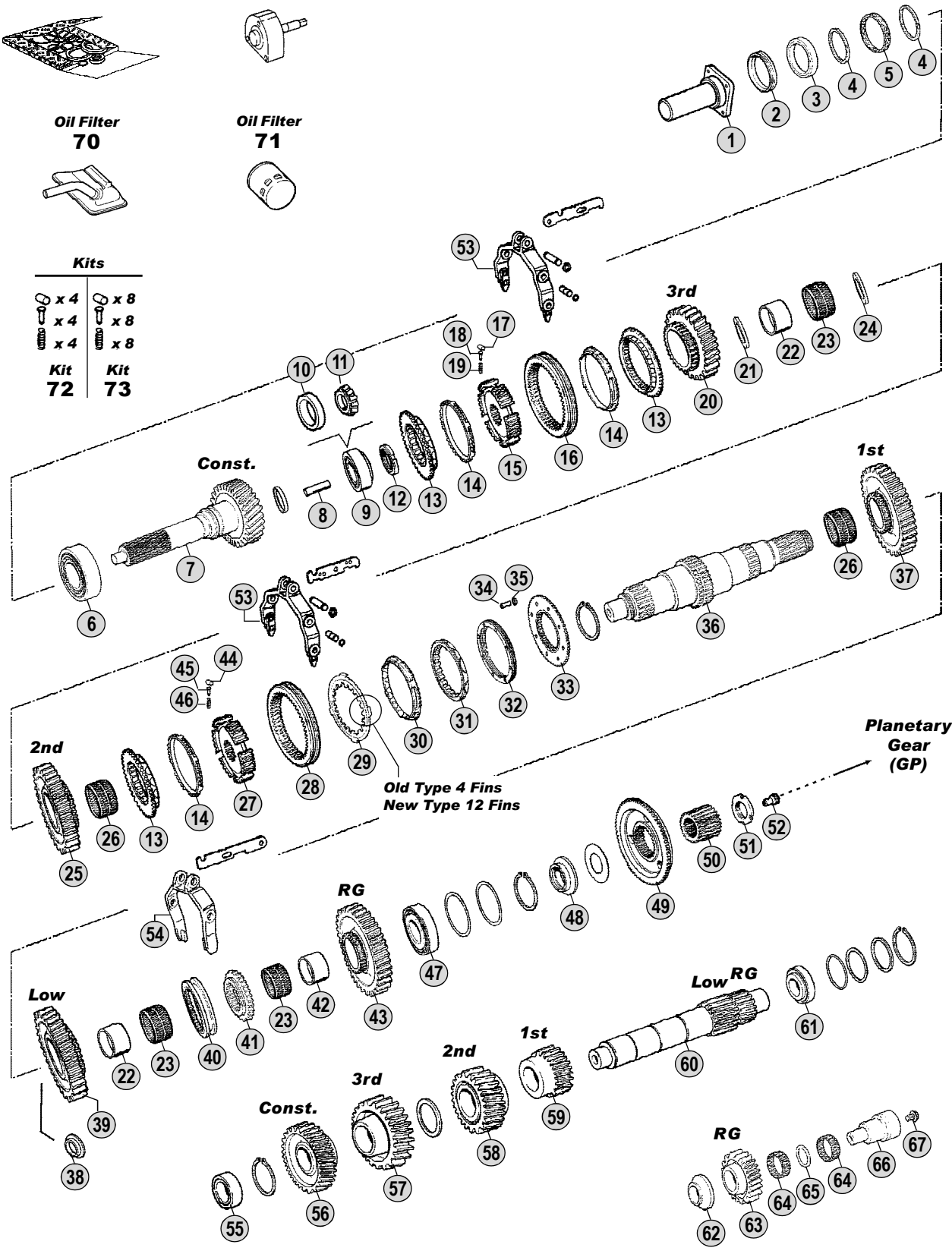

All original equipment manufacturers numbers, symbols, pictures, models and description used in this catalogue are for reference only, and it is not implied that any part listed is the product of these manufacturers. Tutti i nostri particolari non sono originali ma con essi intercambiabili. I riferimenti originali, le figure, i modelli sono esposti a semplice titolo indicativo. La nostra produzione riporta il nostro marchio.

Models

Serie 3 - Serie 4
G93 - P93 - R93 - T93 - P113 - R113 - T113 - R143 - T143
94C/D/G/L - 114C/G/L - 124C/G/L - 144C/G/L



Adattabile a: **SCANIA GR900(H) - GR900R (W/Retarder)**
 Suitable To:

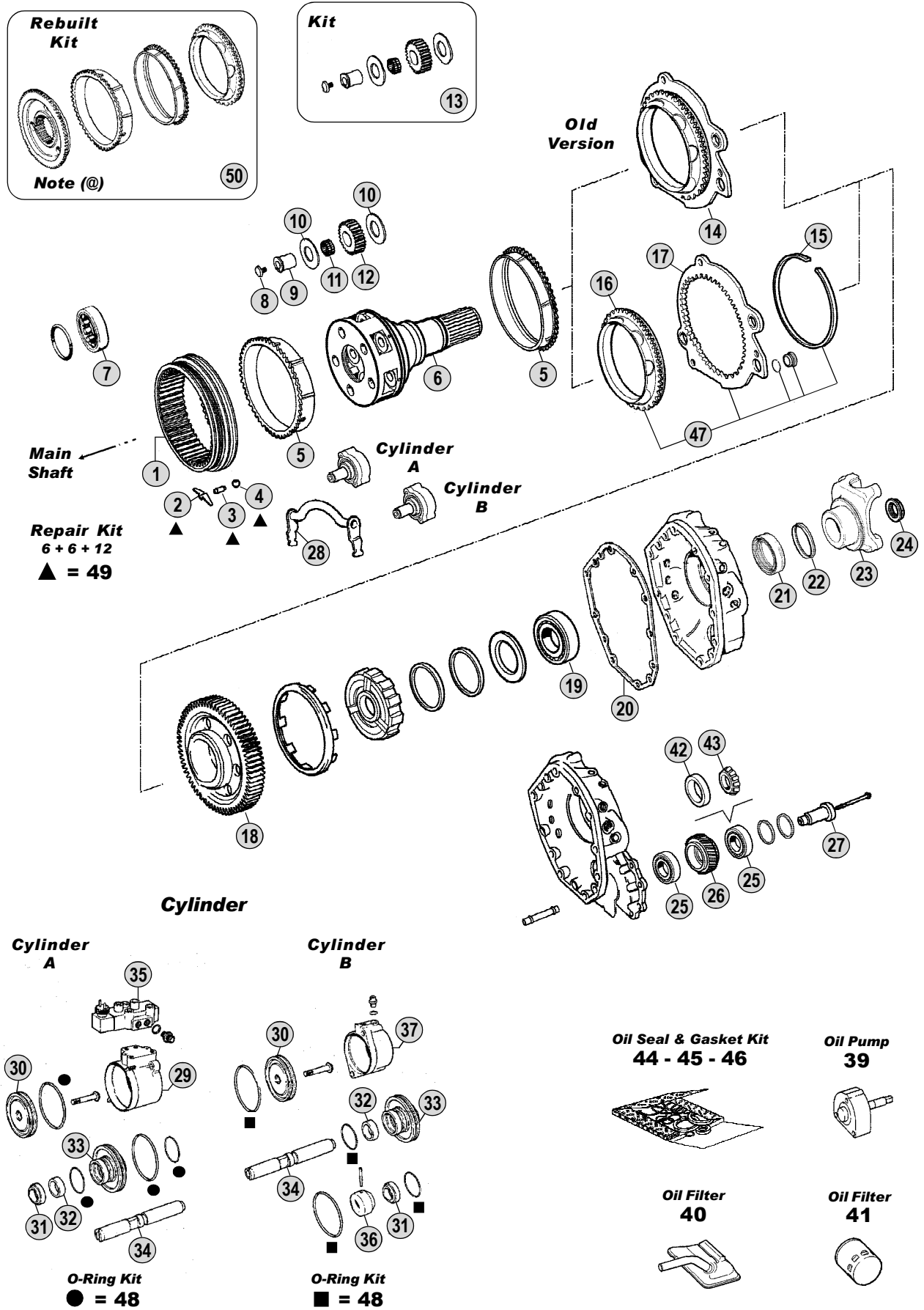

All original equipment manufacturers' numbers, symbols, pictures, models and description used in this catalogue are for reference only, and it is not implied that any part listed is the product of these manufacturers.
 Tutti i nostri particolari non sono originali ma con essi intercambiabili. I riferimenti originali, le figure, i modelli sono esposti a semplice titolo indicativo. La nostra produzione riporta il nostro marchio.

Models

Serie 3 - Serie 4

G93 - P93 - R93 - T93 - P113 - R113 - T113 - R143 - T143

94C/D/G/L - 114C/G/L - 124C/G/L - 144C/G/L



Fig.	CEI no.	Rif. SCANIA	Description	Q.ty	Note						
						GR900	GRH900	GR900R			
1	123.216	1118030	Crown Gear 66 T	1		●	●	●			
2	156.185	1395039	Spring	6		●	●	●			
3	160.215	1332508	Pin	6		●	●	●			
4	160.216	871702	Ball	12		●	●	●			
5	119.121	1395624	Synchronizer Ring	2	(*) Old Generation	●	●	●			
5	119.249	1770058	Synchronizer Ring	2	(*) New Generation	●	●	●			
5	119.288	1883363	Synchronizer Ring	2	(@) Latest Generation	●	●	●			
6	190.332	1318221	Planetary Carrier	1	Complete	●	●				
6	190.333	1318225	Planetary Carrier	1	Complete			●			
7	130.622	1300596	Bearing	1				●			
8	187.606	1318714	Screw	5		●	●	●			
9	107.171	1318713	Pin	5		●	●	●			
10	169.796	389419	Washer	10		●	●	●			
11	137.168	389434	Needle Bearing	5		●	●	●			
12	157.199	1373174	Planet Pinion 20 T	5		●	●	●			
13	198.849	CEI 198849	Repair kit	5		●	●	●			
14	198.982	1308176	Synchro Kit	1	(1) Old Type	●	●	●			
15	111.207	1302665	Snap Ring	1		●	●	●			
16	109.168	1323147	Synchronizer Cone	1	(*) Old Generation	●	●	●			
16	109.421	1788170	Synchronizer Cone	1	(*) New Generation	●	●	●			
16	109.756	1883350	Synchronizer Cone	1	(@) Latest Generation	●	●	●			
17	135.126	1323145	Saddle Plate	1		●	●	●			
18	145.743	1426758	Retarder Gear 70 T	1				●			
19	130.533	1783324	Bearing D.60x130x31	1		●	●	●			
20	139.574	1305139	Gasket	1		●	●	●			
21	139.568	1502384	Oil Seal 85x105x13	1		●	●	●			
22	139.481	1300977	Dust Cover	1		●	●	●			
23	197.106	1340753	Output Flange	1	P30/300	●	●	●			
23	155.198	1422427	Output Flange	1	P40/400	●	●	●			
23	197.107	1422430	Output Flange	1	P50/P500	●	●	●			
23	197.076	1319646	Output Flange	1	P60/P600	●	●	●			
24	187.486	1525988	Nut M44x1,5	1		●	●	●			
25	130.621	361043	Bearing 40x85x33	2	Oem Old Type			●			
25	530.621	361043	Bearing 40x85x33	2	A.Market Old Type			●			
26	145.744	1373704	Gear 34 T	1				●			
27	107.188	1304747	Pin	1				●			
28	141.175	1491403	Fork	1		●	●	●			
29	132.056	1484808	Cylinder	1		●	●	●			
30	189.618	1303960	Piston	2		●	●	●			
31	139.601	1515869	Oil Seal Ring 22X28X5/8	2		●	●	●			
32	117.362	1303799	Bush	2		●	●	●			
33	132.057	1321239	Intermediate Element	2		●	●	●			
34	107.189	1332131	Shaft	2		●	●	●			
35	280.548	1488083	Solenoid Valve	1		●	●	●			
36	117.363	1337828	Sleeve	1		●	●	●			

Notes

(1) Old version replaced by :

1 pc. 135.126 1323145 Saddle Plate (Fig.17)

1 pc. 109.168 1323147 Synchro Cone (Fig.16)

1 pc. 111.207 1302665 Ring (Fig.15)

2 pc. 1305111 Ring + 2 pc. 1305109 Bush (Only in kit - See 198.916)

(*) Old and New Generation. Can be replaced by Synchro rebuilt kit 298.188 (Fig.50)

(@) LATEST GENERATION. To be coupled together.

Date

05 / 2010

Table

0155

Adattabile a: **SCANIA GR900(H) - GR900R (W/Retarder)** Suitable To:

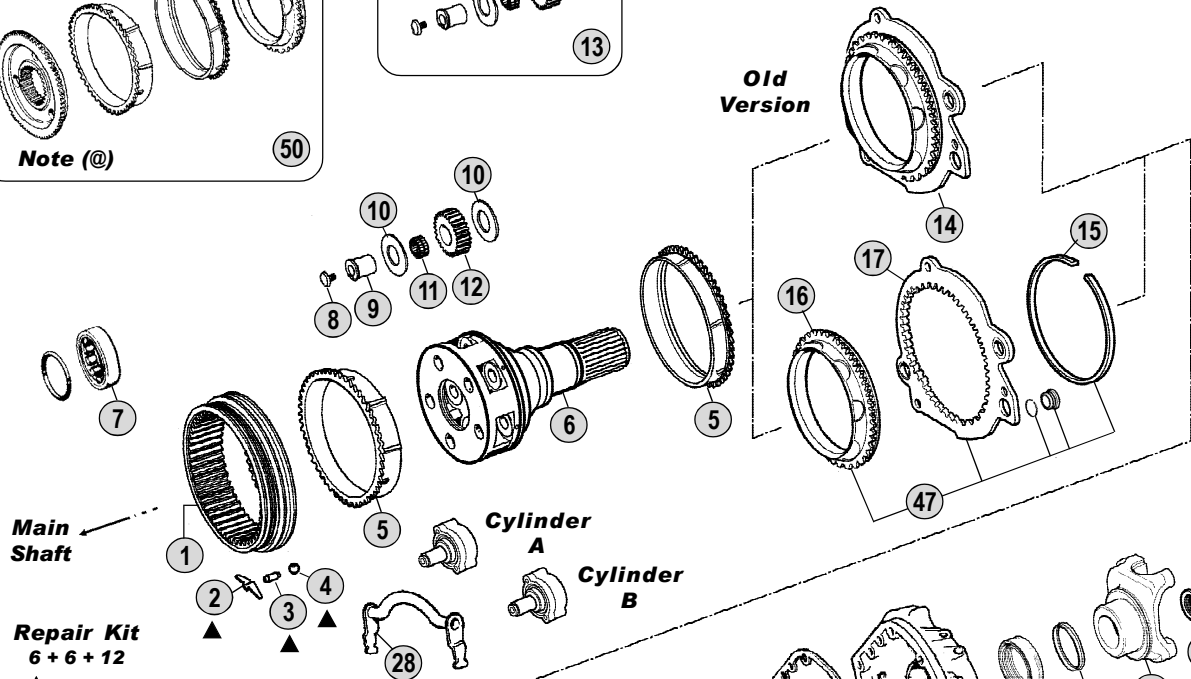
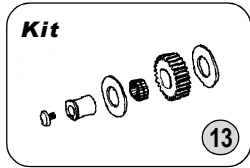
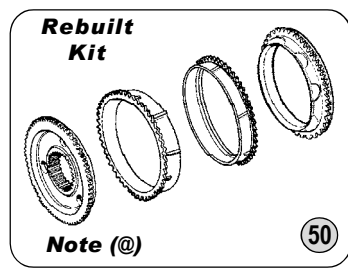

Repair Kit
6 + 6 + 12
▲ = 49

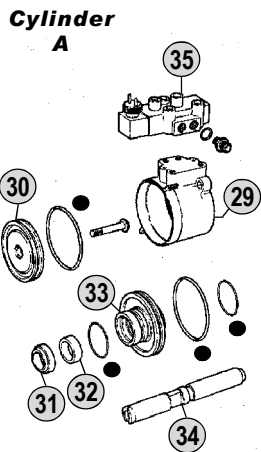
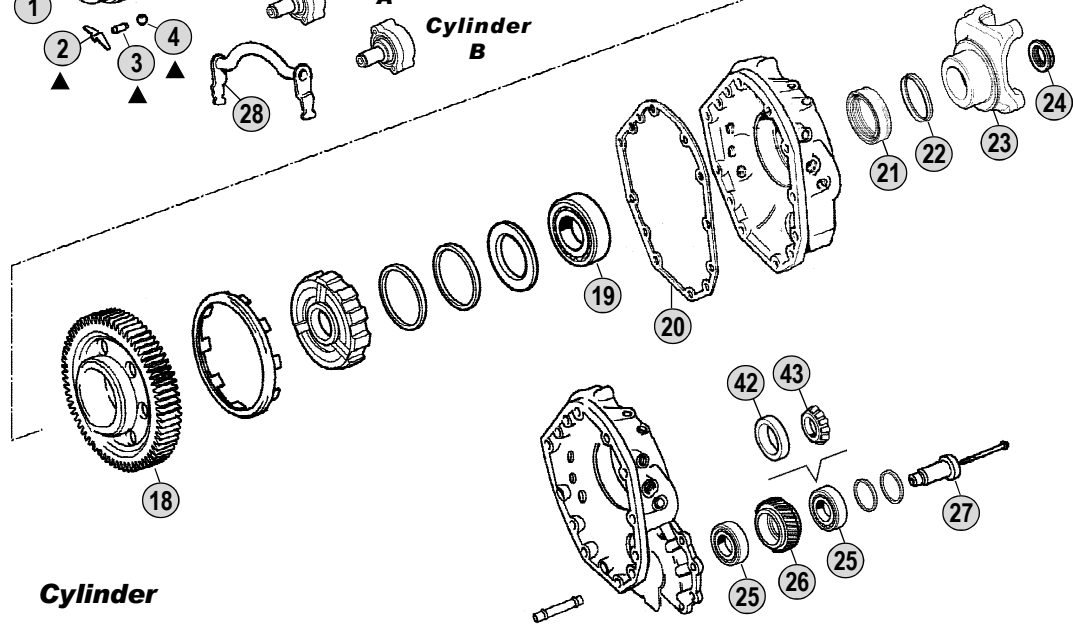

O-Ring Kit
● = 48

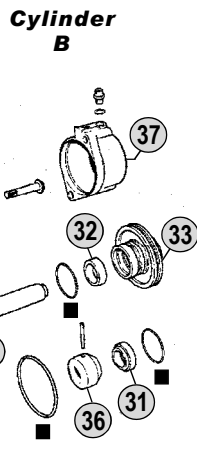

O-Ring Kit
■ = 48

Oil Seal & Gasket Kit
44 - 45 - 46



Oil Filter
40



Oil Pump
39



Oil Filter
41



Models

Serie 3 - Serie 4

G93 - P93 - R93 - T93 - P113 - R113 - T113 - R143 - T143

94C/D/G/L - 114C/G/L - 124C/G/L - 144C/G/L



All original equipment manufacturers' numbers, symbols, pictures, models and description used in this catalogue are for reference only, and it is not implied that any part listed is the product of these manufacturers. Tutti i nostri particolari non sono originali ma con essi intercambiabili. I riferimenti originali, le figure, i modelli sono esposti a semplice titolo indicativo. La nostra produzione riporta il nostro marchio.

